

NEW!

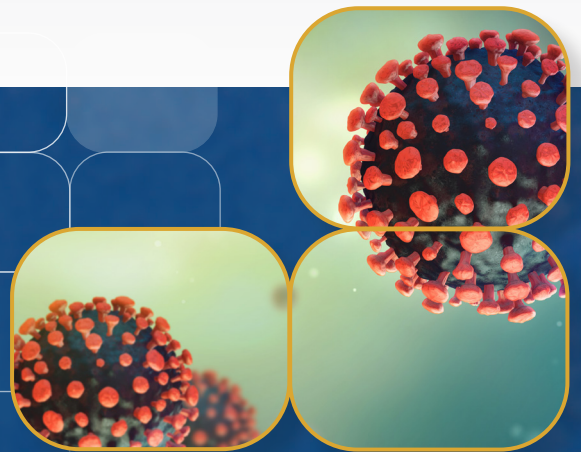

Automatic Hand Sanitizer Dispenser



ESCO

WORLD CLASS. WORLDWIDE.



Refillable Hand Sanitizer Container

- Comes with 1,000 ml liquid capacity and Infrared-sensing automatic hand sanitizer



Receiver Box and Plate

- Receiver box and tray to prevent dripping onto the floor during use



Light Indicator

- LED lights up when switched on, indicating power on.



Power Adaptor and Switch

- Power Adapter DC 6V 1A power supply / or 4 pieces of AA (1.5V) batteries

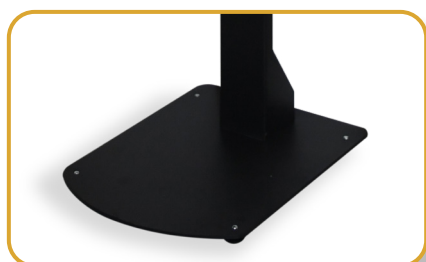

Durable Floor Stand

- Durable painted steel.



Engineering Drawing

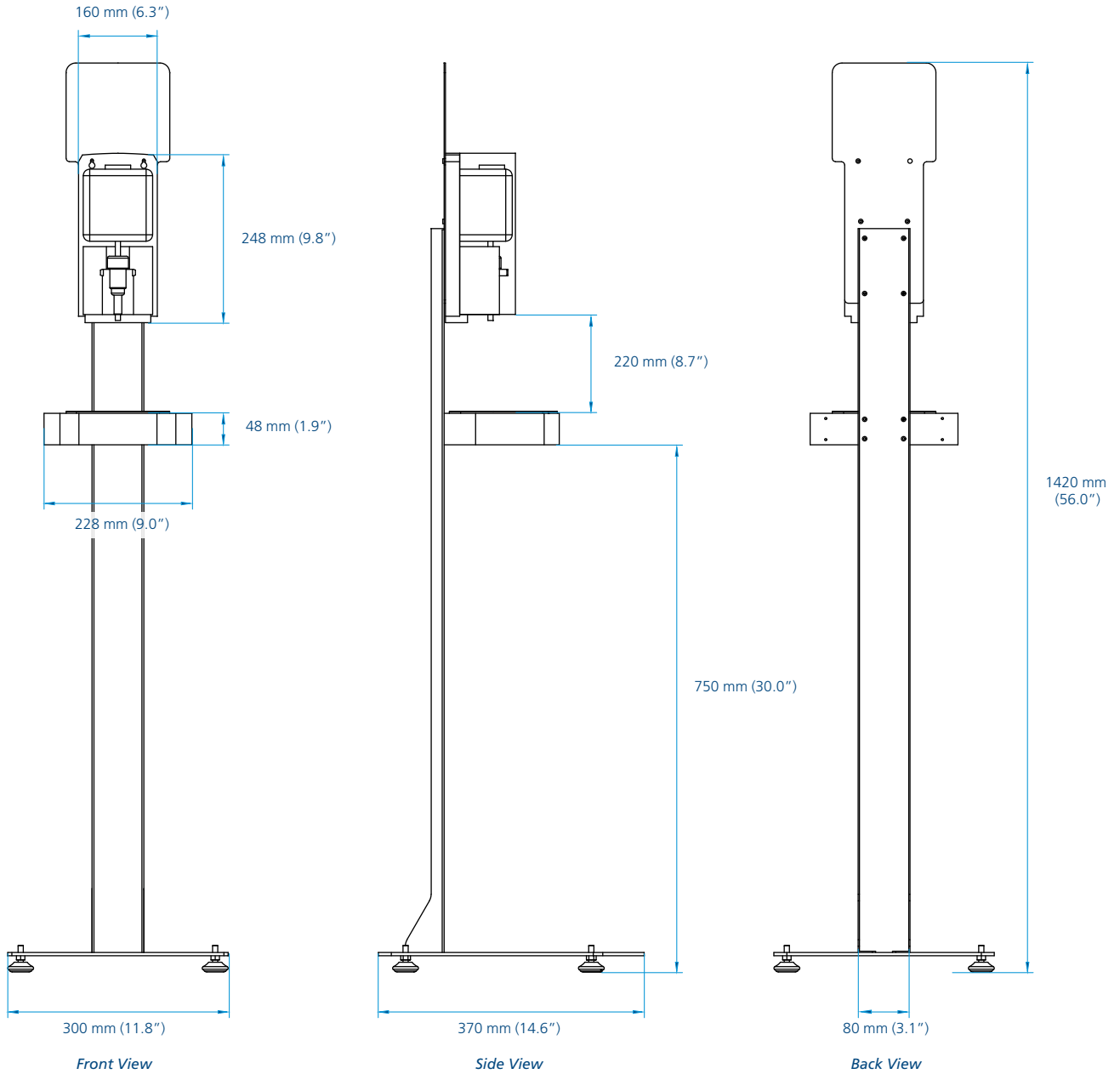

Esco Automatic Hand Sanitizer Dispenser		
Model	ASD-W	Wall-mounted
	ASD-S	Stand-mounted
Sensing method	Infrared auto-sensing	
Sensing range	0-10 cm (3.9")	
Response time	25 ms	
Power supply	4 pieces non-rechargeable AA battery (1.5V) or DC6V 1A power supply (optional and can not use with battery)	
Liquid capacity	1000 ml	
Spraying volume	1.2ml (Spray)	
Liquid exchange method	Manual open cover to replace liquid	
Shell material	Environmental ABS materials	
Workplace	Indoor	

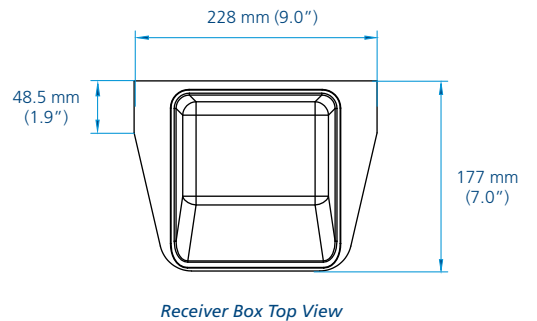

ESCO GLOBAL NETWORK

42 LOCATIONS IN 21 COUNTRIES ALL OVER THE WORLD

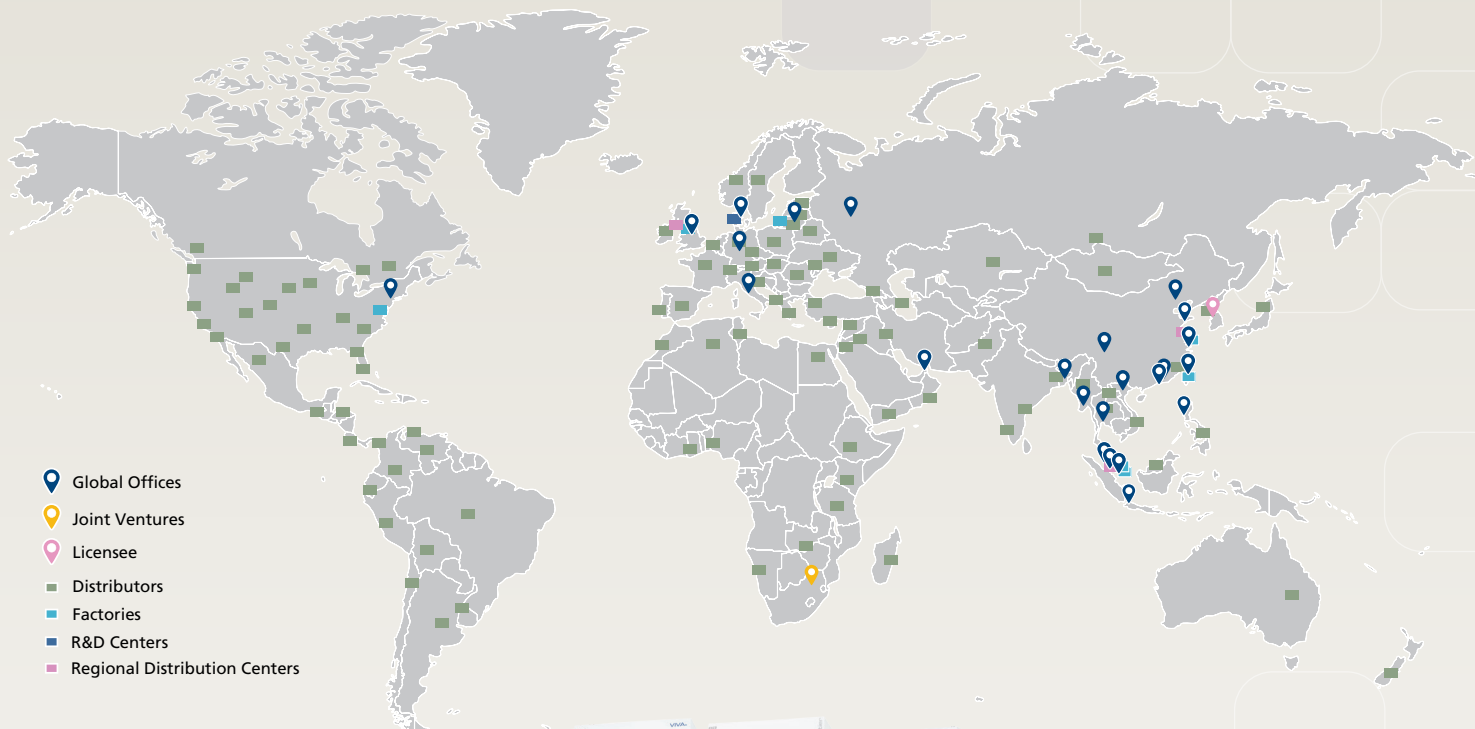

- ART Equipment
- Biological Safety Cabinets
- CO₂ Incubators
- Compounding Pharmacy Equipment
- Containment / Pharma Products
- Ductless Fume Hoods
- Lab Animal Research Products
- Laboratory Centrifuges
- Laboratory Fume Hoods
- Laboratory Ovens and Incubators
- Laboratory Shakers
- Laminar Flow Clean Benches
- PCR Cabinets
- PCR Thermal Cyclers
- Powder Weighing Balance Enclosures
- Ultra-low Temperature Freezers

The Esco Group of Companies is a global life sciences tools provider with sales in over 100 countries. The group is active in lab equipment, pharma equipment and medical devices. Manufacturing facilities are located in Asia and Europe. R&D is conducted worldwide spanning the US, Europe and Asia. Sales, service and marketing subsidiaries are located in 12 major markets including the US, UK, Singapore, Japan, China and India. Regional distribution centers are located in the US, UK, and Singapore.

Life Science • Chemical Research • Assisted Reproductive Technology (ART) • Pharmaceutical Equipment • General Equipment



WORLD CLASS. WORLDWIDE.

Esco Micro Pte. Ltd. • 21 Changi South Street 1 • Singapore 486 777
 Tel +65 6542 0833 • Fax +65 6542 6920 • mail@escoglobal.com
 www.escoglobal.com

Esco Technologies, Inc. • 903 Sheehy Drive, Suite F, Horsham, PA 19044, USA
 Tel 215-441-9661 • Fax 484-698-7757
 eti.admin@escoglobal.com • www.escolifesciences.us

Esco Global Offices: Bangladesh | China | Denmark | Germany | Hong Kong | Indonesia | Italy | Lithuania | Malaysia | Myanmar | Philippines | Russia | Singapore | South Africa | South Korea | Taiwan | Thailand | UAE | UK | USA | Vietnam

